

OEM MASS FLOW SWITCH Installation and Operation Guide

INSTRUMENT INSTALLATION

The OEM Mass Flow Switch is an insertion instrument capable of monitoring gas or liquid flow in a wide range of processes for purposes of switching at a preset alarm switch point. This set point is fully adjustable in the field. The instrument can be top or side mounted. The process connection is male 1/4 inch NPT (or 1/2 inch NPT compression fitting). See the installation outline drawing below for mounting dimensions.

There is an orientation mark etched onto the hexagonal surface of the element. The flow element must be located with the orientation mark parallel to flow. Apply an appropriate sealant to the male threads when connecting the flow element to the process. Tighten the element until it is hand tight. Use a wrench to rotate the element until the flow arrow on the hexagonal flat is in the direction and parallel to flow, $\pm 2^\circ$. The enclosure should be located so that the conduit port is in a downward direction. This is to prevent moisture from collecting in the enclosure.

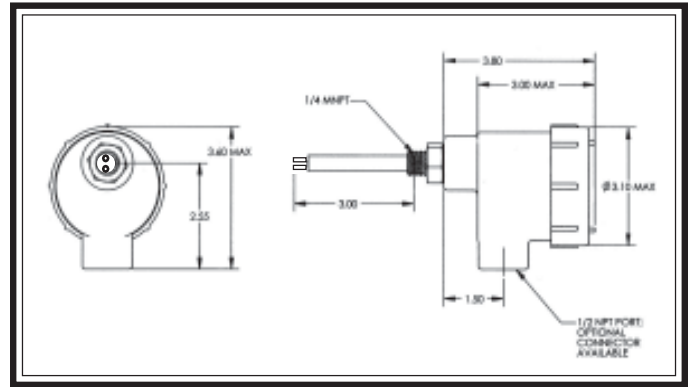

Installation Outline Diagram

INSTRUMENT WIRING

Caution: Only qualified personnel are to wire or test this instrument. The operator assumes all responsibilities for safe practices while wiring or troubleshooting.

Alert: The instrument contains electrostatic discharge (ESD) sensitive devices. Use standard ESD precautions when handling the flow transmitter.

Recommended Minimum AWG Wire Table

Connection	Maximum Distance for AWG			
	10 ft. (3M)	50 ft. (15M)	100 ft. (76M)	250 ft. (76M)
Input Power	22	20	18	16
4-20 Output (600 Ohm Max.)	18	18	16	14
Voltage Output	18	16	N/R	N/R

Use the following steps to wire the instrument:

- FCI recommends installing an input power disconnect switch and fuse near the instrument to interrupt power during installation, maintenance, calibration, alarm selection and troubleshooting procedures.
- Ensure the power is off to the instrument before wiring the instrument.
- Conduit or other protective sheathing should be connected to the 1/2 inch ports of the enclosure. See the above Minimum AWG Wire Table to determine the size of wire to use versus the distance the wire has to be run.

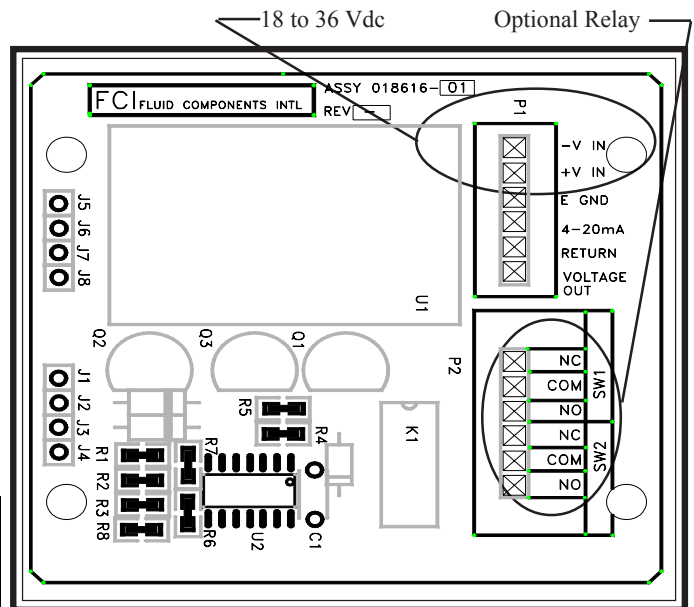

Customer Wiring Diagram

- Unscrew and remove the top cover of the instrument. Lift the circuit board assembly by pulling up on the white plastic pull tie wrap. The customer connections are near the top of the circuit board. Be careful not to stress the wires that are connected to the circuit board.
- Connect 24 VDC input power to P1 +V IN and -V IN.
- Connect the 4-20mA output terminals as required.
- Push the board back into the enclosure and replace the top cover.
- Turn power on to operate the instrument.

TROUBLESHOOTING

Verify that the wiring is correct. Contact FCI Technical Service if problems still persist. The Telephone Number is 1 800 854-1993, or (760) 744-6950.

GENERAL SPECIFICATIONS

Material of Construction:	Element; 300 Series Stainless Steel Enclosure; Diecast Epoxy Coated Aluminum.
Operating Temperature:	Flow Element; Low Temp. -40 to +350°F (-40 to +177°C) High Temp. to 500 °F (260°C) Electronics; -40 to +140°F (-40 to +60°C)
Safety Proof Pressure:	500 psig.
Input Power:	18 - 36 Vdc
Repeatability:	0.5% of reading
Mounting:	Vertical or horizontal
Service:	Air or gas (depends on calibration)
Enclosure Classification:	UL Class 1 and 2, Div 1 & 2, Groups C, D, E, F, G
Approvals:	CE Mark

ALARM SWITCH POINT SET-UP

The set point may be adjusted blindly or with a volt meter to see relative flow and establish a reference point.

In RUN MODE:

0-25mA related to flow.

0-10Vout related to temperature.

Green LED on = power on (run mode).

Red LED indicates fail-safe setting.

Red LED ON = relay de-energized on flow (or wet condition) **BELOW** the alarm set point.

Red LED OFF = relay de-energized on flow (or dry condition) **ABOVE** the alarm set point.

CALIBRATION MODE:

To enter calibration mode, press both buttons simultaneously once.

Both LED's will be off.

Use either output to monitor the alarm set point.

0-10Vout represents the Set Point.

0-25mA represents the Set Point.

Press both buttons simultaneously to exit CALIBRATION MODE and toggle the fail-safe mode.

The Green LED is on and the Red LED is either on or off, indicating fail-safe setting as described above.

To change fail-safe setting, press both buttons simultaneously twice.

Notice of Proprietary Rights

This document contains confidential technical data, including trade secrets and proprietary information which are the property of Fluid Components Intl (FCI). Disclosure of this data to you is expressly conditioned upon your assent that its use is limited to use within your company only (and does not include manufacture or processing uses). Any other use is strictly prohibited without the prior written consent of FCI.

Visit FCI on the Worldwide Web: www.fluidcomponents.com

1755 La Costa Meadows Drive, San Marcos, California 92069 USA - 760-744-6950 - 800-854-1993 - Fax 760-736-6250