

## OEM MASS FLOW METER: Configuration -2A1 Installation and Operation Guide

### INSTRUMENT INSTALLATION

The OEM Mass Flow Meter is an insertion instrument capable of measuring air and gas flow in a wide range of processes. The instrument can be top or side mounted. The process connection is male 1/4 inch NPT (or 1/2 inch NPT compression fitting). See the installation outline drawing below for mounting dimensions.

There is an orientation mark etched onto the hexagonal surface of the element. The flow element must be located with the orientation mark parallel to flow. Apply an appropriate sealant to the male threads when installing the flow element and securing enclosure cover. Tighten the element until it is hand tight. Use a wrench to rotate the element until the flow arrow on the hexagonal flat is in the direction and parallel to flow,  $\pm 2^\circ$ . If possible, it is recommended the enclosure be located such that the conduit port is in a downward direction to reduce the opportunity of moisture collecting in the enclosure.

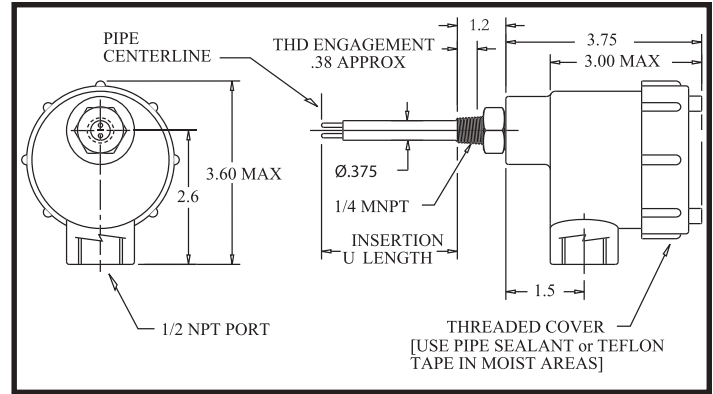

Installation Outline Diagram

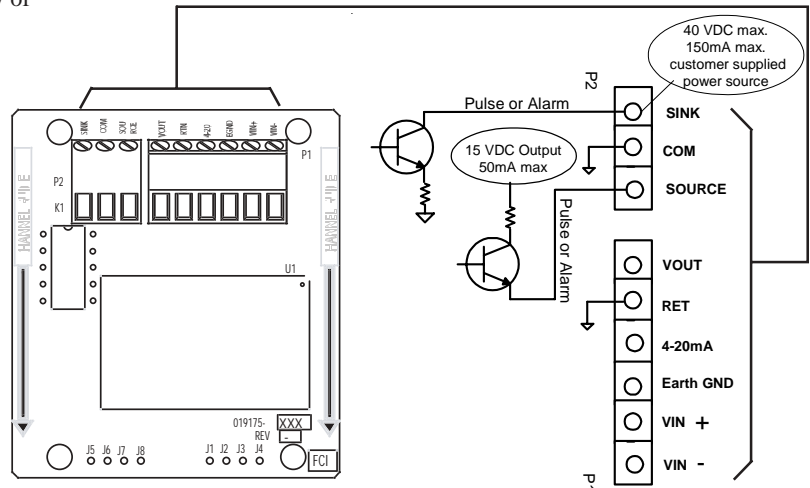
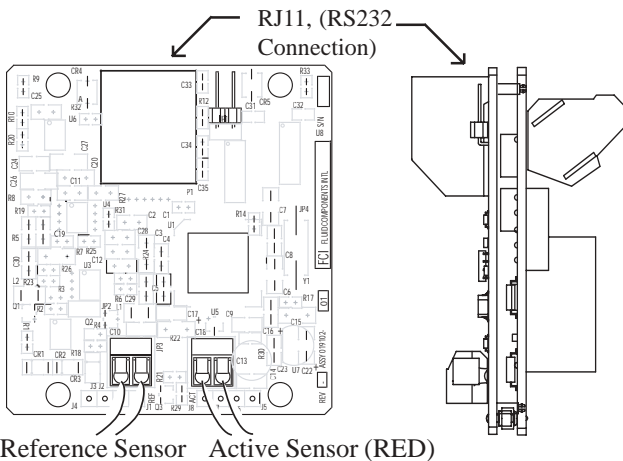

Instrument Wiring



#### Caution:

Only qualified personnel are to wire or test this instrument. The operator assumes all responsibilities for safe practices while wiring or troubleshooting.



#### Alert:

Use standard ESD (electrostatic discharge) precautions when handling the transmitter circuit board.

Use the following steps to wire the instrument:

- FCI recommends installing an input power disconnect switch and fuse near the instrument to interrupt power during installation, maintenance, calibration, alarm selection and troubleshooting procedures.
- Ensure the power is off before wiring the instrument.
- Conduit or other protective sheathing should be connected to the 1/2 inch port of the enclosure.
- Unscrew and remove the top cover of the instrument. Lift the circuit board assembly by pulling up on the white plastic pull tie wrap. The customer connections are near the top of the circuit board. Be careful not to stress the wires that are connected to the circuit board.

- Connect 24 VDC input power to P1 +V IN and -V IN.
- Connect the 4-20mA output terminals as required.
- Connect pulse or alarm output if desired (source or sink mode). Refer to specifications and setup on following pages.
- Push the board back into the enclosure and replace the top cover.
- Turn power on to operate the instrument.

### TROUBLESHOOTING

Verify that the wiring is correct. Contact FCI Technical Service if problems still persist. The telephone number is (800) 854-1993, or (760) 744-6950.

## GENERAL SPECIFICATIONS

Material of Construction:	Element; 300 Series Stainless Steel, Enclosure; Diecast Epoxy Coated Aluminum.
Operating Temperature:	Flow Element; -40 to +250°F (-40 to +121°C) Electronics; -40 to +140°F (-40 to +60°C)
Safety Proof Pressure:	500 psig.
Input Power:	9.5 to 36 Vdc, 3.5 watts nominal
Output Current:	4-20mA, 500 ohm maximum - scalable from 20:1 to 100:1 turndown of calibrated flow
Output Voltage:	0-10 VDC, 10K ohm minimum input impedance, directly related to temperature or flow
Output Pulse Source:	Totalized flow or alarm set point. 15VDC. Pulse width at 50% duty cycle for rates 1 to 500Hz, 0.5 second pulse width for pulse rates below 1 Hz. 25mA maximum load pulsed, 10mA maximum load if state set to normally on.
Output Pulse Sink:	Totalized flow or alarm set point. Pulse width at 50% duty cycle for rates 1 to 500Hz, 0.5 second pulse width for pulse rates below 1 Hz. Customer power source and load not to exceed 40VDC and 150mA.
Pulse Factor Setting:	0.001 to 1000 factor of full scale flow rate (not to exceed 500 Hz). Default = 1.
Pulse Sample Period:	0.5 to 5.0 seconds. Default = 1 second
Alarm set point hysteresis:	2% of set point
Repeatability:	0.5% of reading
Mounting:	Vertical or horizontal
Service:	Air or gas (depends on calibration)
Flow Range:	.25 to 800 SFS (depends on calibration)
Enclosure Classification:	UL Class 1 and 2, Div 1 & 2, Groups C, D, E, F, G
Approvals:	CE Mark

### Configuration options:

4-20mA out:	Mass Flow/Volumetric Flow or Temperature
0-10V out:	Mass Flow/Volumetric Flow or Temperature (default temperature output range is -40 to 250°F [-40 to 121°C]).
Source out:	Pulse (totalizer), or Alarm Function (set-point). Pulse out factorable from 0.001 to 1000 of set flow units, high or low state.*
Sink out:	Pulse (totalizer), or Alarm Function (set-point). Pulse out factorable from 0.001 to 1000 of set flow units, high or low state.*

\* **Default pulse factor** is set to 1. For example, if meter is configured in SCFM, then each pulse out will represent 1 SCF. Maximum frequency of pulse output is 500Hz., therefore, pulse factor must not be set to levels that will exceed this level at maximum flow. i.e. if max. flow = 100 SCFM, @ pulse factor (PF) = 1, pulse rate = 1.667 Hz. @ PF 0.1 = 16.67 Hz, @ PF 0.01 = 166.7 Hz. However, pulse factor 0.001 results in 1667 Hz -- which exceeds limit of 500 Hz. The **pulse sample period** is the period for updating the accumulated flow from the internal totalizer. Pulses are output within this period at a frequency calculated based on the pulse factor setting. In-between pulses are saved and output in the next cycle (pulses are never lost). The pulse output signals can be independently configured to change from "high" to "low" state or "low" to "high" state. See Table 4.

### Setup Interface

All parameters on this meter are set through the RS232 interface connection (RJ11 plug). An FCI model FC88 handheld calibrator or direct computer interface may be used to access these parameters. The FC88 is powered through the meter and comes with the serial interface cable. If a computer interface is used, an adapter cable (RJ11 to 9 pin Computer Serial Port) is required and may be obtained from FCI: Part No. 014108-02.

Using Windows Terminal (usually located in Accessories) execute the program by double-clicking on the Terminal Icon.

1. Go to *Settings*.
2. Click on *Communication*.
3. Set for COM1 or COM2, 9600 Baud, 8 Bit, and No Parity. Press OK
4. Press the *ENTER* key to see the *Input Mode?* prompt.
5. Enter any of the Meters single letter commands to execute a function (reference function menu on following page).

### Menu Control and Organization

Most entries require at least two key strokes; a Capital letter and the [ENTER] key, or one or more numbers and the [ENTER] key. All user entries begin at the Input Mode?< prompt except when the instrument is in the Main Function Mode (just press the desired function letter and [ENTER] to make an entry).

A user entry is indicated by brackets [ ] being placed around the entry. Y/N refers to Yes (Y), save or change parameter or No (N) do not save or change parameter unless otherwise specified. Backspaces are made using the backspace [BKSP] key. Some entries are case sensitive between numbers and letters. Be sure the SHIFT key is pressed to indicate the correct case. A square after the prompt caret indicates the FC88 is in lower case. A slightly raised rectangle in the same spot indicates the FC88 is in the upper case. It is recommended that the FC88 be plugged into the instrument before power is applied. If the FC88 is plugged in while the instrument power is on and the FC88 does not respond, press [ENTER], if there is no response press [P], if there is still no response Press [N].

**Note:** The Zero and Span may be changed from the original calibration, provided new values are within the original calibrated range. i.e. if original calibration was 1 to 100 SCFM (4-20mA), new zero must be equal or greater than 1 SCFM, new span must be equal or less than 100 SCFM.

Some entries require a Factory pass code (Contact FCI Field Service) to continue programming the instrument. The instrument will prompt the user when this is necessary. Do not change any parameters that require this code unless there is an absolute understanding of the instrument's operation. The user can not exit some routines unless all entries are completed or the power is recycled.

The top level of the menu is shown below. Enter the large letter in the tables below to activate a command.

**Table 1**

Customer Settings	
<b>T</b>	<b>Normal Operation Mode</b> All outputs active
<b>F</b>	<b>K Factor</b> (1 is default)
<b>Z</b>	<b>Flow Units Set-up</b> Select flow units (4 English, 4 Metric), Pipe diameter and span/zero settings
<b>W</b>	<b>Totalizer Mode</b> <b>Disable/Enable internal totalizer</b>
<b>V</b>	<b>Output Configuration Selection</b> Select one of four output configurations: pulse and/or alarm, plus pulse factor and/or set point
<b>N</b>	<b>Warm Reset</b> Re-initialize instrument without removing power

**Table 2**

Diagnostics and Factory Settings	
<b>C</b>	<b>Calibration Information</b> Display only: A/D, Delta-R, Ref-R data values
<b>D</b>	<b>Diagnostics</b> Display only: Check-out of functional conditions
<b>K</b>	<b>Factory Calibration Settings</b> Display only: Cal. parameters, i.e. linearization and temperature compensation coefficients.
<b>L</b>	<b>Calibrate Outputs</b> Factory Access Only
<b>Y</b>	<b>Command Line Interface</b> Factory Access Only
<b>R</b>	<b>Factory Reset</b> Replaces user data with factory calibration data

User may exit command at any time entering "Q" [ENTER] in menus: D, K, L, V, W, or Z.

**Table 3**

"Z" Flow Units Set-up and Scaling		
Units		
Select	E=English	M=Metric
Select	F= SFPS	M=SMPS
or	C = SCFM	N = NCMH
or	H = SCFH	O = NCMM
or	L = LBS/H	K = KG/H
<b>For Volumetric or Mass Flow</b>		
Select	R = Round pipe or duct	
or	S = Square duct	
Set	Diameter or Wide X High (in inches or mm)	
Set	Max = Maximum flow rate (span)	
Set	Zero = Minimum flow rate (zero)	

Note: Changing units requires rescaling the unit (set new zero and span).

**Table 4**

"V" Output Configuration Set-up					
<u>Analog out</u>					
	Select	<u>1</u>	<u>2</u>	<u>3</u>	<u>4</u>
4-20mA out	Flow	Flow	Temp	Temp	
0-10 Vout	Temp	Flow	Flow	Temp	
<u>Pulse out</u>					
	Select	<u>1</u>	<u>2</u>	<u>3</u>	<u>4</u>
Source out	Pulse	Pulse	Alarm0	Alarm0	
	Set	Factor	Factor	Set pt.0	Set pt.0
	Set	Period	Period	State0	State0
	Set	State0	State0		
Sink	Pulse	Alarm1	Pulse	Alarm1	
	Set	Set pt.1	Factor	Set pt.1	
	Set	State1	State1	Period	State1
			State1		

**Analog out**  
Output Mode Selected  
4-20mA: Flow  
0-10V: Temp  
Change? (Y/N)>  
4-20mA: Flow  
0-10V: Temp  
Enter 1 to make the selection\_\_  
4-20mA: Flow  
0-10V: Flow  
Enter 2 to make the selection\_\_  
4-20mA: Temp  
0-10V: Flow  
Enter 3 to make the selection\_\_  
4-20mA: Temp  
0-10V: Temp  
Enter 4 to make the selection\_\_

*Display comes up to last setting saved and stays for 2 seconds. If N or [ENTER], proceed to Pulse out. If Y, display moves to selection options and asks for confirmation. If you miss the option, select [Enter] repeatedly to loop around.*

**Pulse out**  
Pulse Out Selected  
Source: Pulse  
Sink: Pulse  
Change? (Y/N)>  
Source: Pulse  
Sink: Pulse  
Enter 1 to make the selection #\_\_  
Source: Pulse  
Sink: Alarm1  
Enter 2 to make the selection #\_\_  
Source: Alarm0  
Sink: Pulse  
Enter 3 to make the selection #\_\_  
Source: Alarm0  
Sink: Alarm1  
Enter 4 to make the selection #\_\_

PFactor: 1.000  
Change? (Y/N)>  
if yes  
Enter new factor: \_\_\_\_  
Sample Period: 1 second  
Change? (Y/N)>  
if yes  
Enter new Sample Period: \_\_\_\_

*If alarm is a selected output*  
Set point1: 000 Set points are in the same units as the flow or temp.  
Change? (Y/N)>  
if yes  
Enter new set point: \_\_\_\_  
Resume normal operation  
Source state: 0  
Change to 1?>  
Sink state: 1  
Change to 0?>

**General Navigation Note:** Pressing [Y] [ENTER] acknowledges a change to the existing setting or toggles the current setting. Pressing [ENTER] alone, moves to the next menu item.

### Example: COMMAND Z (Reference Table 3)

#### Case: Volume (English) in SCFM, Round pipe

Pressing [Z] [ENTER] will display “E for English or” followed by “M for Metric.” Press an [E] [ENTER].

The next prompt is **0=SFPS, 1=SCFM**

**2=SCFH, 2=LBS/H#** Press [1] [ENTER].

The next prompt is “R round duct or” followed by “S rectangular <.” Press [R] [ENTER].

The next prompt is “Diameter: inches” “x.xxxxxx” followed by “Change it ?<.” Press [Y] [ENTER].

Enter a new value or else press [N] [ENTER] or [ENTER].

The next prompt is “Max = xxx.xxxxxx” followed by “Change F.S.?<.” Press [Y] [ENTER]

Enter a new value or else press [N] [ENTER] or [ENTER].

The next prompt is “Zero = x.xxxxxx” followed by “Change it ?<.” Press [Y] [ENTER]

Enter a new value or else press [N] [ENTER] or [ENTER].

The last prompt is “Input mode ?<.”

Enter “T” to resume normal operation.”

*Note: The output may be scaled anywhere between 10:1 to 100:1 of original factory calibration.*

### Example: COMMAND V (Reference Table 4)

#### Case: 4-20mA = flow, 0-10V = Temperature, Source Out = Pulse, Sink = Alarm

Pressing [V] [ENTER] will display “Output Mode Selected” followed by:

“4-20mA = Flow” “0-10V = Temp” followed by

“Change? (Y/N)”

Press [ENTER] (no change).

The last saved mode will display at this point. i.e.,

“Source: Pulse” “Sink: Pulse” followed by,

“Change? (Y/N)” Select Y [Enter]. The display reads,

“Source: Pulse” “Sink: Pulse” followed by,

“Enter 1 to make the selection #.” Select [ENTER]. The next display reads,

“Source: Pulse” “Sink: Alarm” followed by,

“Enter 2 to make the selection #.” Select 2 and [ENTER]. The next prompt reads,

“PFactor: 1.000” “Change? (Y/N)>” (this factor can be anywhere from 0.001 to 1000 - Refer to *Configuration*

*options* on page two for definition of factor). If no change, select N and/or [ENTER] to continue. The next prompt is,

“Sample Period” “Change? (Y/N)>” (this value may be set from 0.5 to 5 seconds - Refer to *Configuration options*

on page two for definition of sample period). If no change, select N and/or [ENTER] to continue. The next prompt is,

“Source state: 1” “Change to 0?>” (this selection toggles the pulse signal normally high or normally low).

[ENTER] to read display.

“Switchpt1” “0.000000” the current set point.

“Change? (Y/N)>” enter Y [ENTER] and enter #\_\_\_\_\_. Set Point Value, i.e. 50 (value is in same units as the flow and must be within the calibrated range). [ENTER]. The next prompt is,

“Sink state: 1” “Change to 0?>”. Set the output signal to be normally “High” or normally “Low.” Pressing [Y]

[ENTER] toggles the current setting. Pressing [ENTER] resumes normal operation.

#### Notice of Proprietary Rights

This document contains confidential technical data, including trade secrets and proprietary information which is the property of Fluid Components International LLC (FCI). Disclosure of this data to you is expressly conditioned upon your assent that its use is limited to use within your company only (and does not include manufacture or processing uses). Any other use is strictly prohibited without the prior written consent of FCI.

Visit FCI on the Worldwide Web: [www.fluidcomponents.com](http://www.fluidcomponents.com)

1755 La Costa Meadows Drive, San Marcos, California 92069 USA - 760-744-6950 - 800-854-1993 - Fax 760-736-6250