NuTec Series Flow & Level Monitoring Switch Installation and Operation Guide

Quick Installation and Adjustment Overview

Section A - Instrument Description and Identification

Section B - Instrument Installation

Install the instrument on to the application in the orientation required. Take extra precaution not to damage the sensing elements/surface. If wiring conduit is required, make sure there are no obstructions leading to the wiring ports. Check for leaks.

Section C - Instrument Wiring

Verify the power and output load requirements for the instrument and install the proper wire size for the application. Wiring to relays will require knowledge of the alarm state and load circuit. Take extra precaution not to damage the control circuits.

Section D - Power Up, Functional Verification and Adjustment.

Before applying power to the instrument, inspect the installation workmanship. In most cases the instrument will detect a flow or level alarm with the factory settings. If the instrument does not respond, responds slowly or the alarm responds opposite to the required indication, follow the adjustment procedure in this section or go to Section E.

Section E - Maintenance and Troubleshooting

Section F - Approval Information

Section A - Instrument Description and Identification

Thoroughly understanding the capabilities of the NuTec instrument, and its intended use for your application, will make the installation much easier. This installation guide describes the four NuTec models available.

LS2000

The model LS2000 is an insertion instrument capable of detecting liquid levels or product interfaces in a wide range of processes. The instrument can be top or side mounted. The process connection choices are male ¼ inch NPT, ¾ inch NPT or 1-1/2 inch, 150 lb. Flange. See the installation outline drawings on page 3 or 4 for the correct mounting dimensions.

FS2000

The model FS2000 is an insertion instrument capable of detecting flow / no-flow in a wide range of processes. The instrument can be top or side mounted. The process connection choices are male ¼ inch NPT, ¾ inch NPT or 1-1/2 inch, 150 lb. flange. See the installation outline drawings on page 3 or 4 for the correct mounting dimensions.

FS2000H

The model FS2000H is an insertion instrument capable of detecting flow/no-flow in a wide range of processes. This probe offers our highest range for flow detection. This probe is not required to protrude into the process flow, but can be inserted even with the pipe inside diameter and still offer extended flow ranges. The process connection is a 1" NPT male thread. See the installation outline drawings on pages 3 and 4 for the correct mounting dimensions.

FS2000L

The model FS2000L is a non-intrusive, in-line instrument capable of monitoring the flow rate of a wide range of gas or liquid processes. The instrument can be mounted vertically or horizontally. The process connection choices are male NPT, butt weld or sanitary flange. See the installation outline drawings on page 3 or 4 for the correct mounting dimensions.

SPECIFICATIONS

<p>Model: FS2000 Insertion Flow Switch (I)³ LS2000 Insertion Level Switch (II)³ FS2000H Insertion Flow Switch, High Flow Rate (III)³ FS2000L In-Line Flow Switch, Non-Intrusive (IV)³</p>	<p>LS2000 Level Switch</p> <p>Accuracy: Top Mount: ± 0.250 inch [± 6mm] from element tip Side Mount: ± 0.125 inch [± 3mm] from centerline of element tip</p> <p>Response Time: Dry to Wet: Less than 2 seconds Wet to Dry: Less than 5 seconds Wet to Wet (interface): Less than 10 seconds</p>												
<p>Material of Construction: 304/305 or 316L Stainless Steel (I & II) 316L Stainless Steel (III & IV)</p>	<p>FS2000 Flow Switch</p> <p>Setpoint Range: Water: 0.1 – 1.5 fps [0.03 – 0.45 mps] Hydrocarbon: 0.1 – 2.0 fps [0.03 – 0.60 mps] Air: 0.5 – 100 sfps [0.15 – 30 nmms]</p> <p>Repeatability: ± 1% of Setpoint Range</p> <p>Response Time: 0.5 – 2.5 Seconds</p>												
<p>Operating Temperature: Sensor Element: -40° to +250°F [-40° to +121°C] Control Circuit: -0° to +140°F [-18° to +60°C]</p>	<p>FS2000H Flow Switch</p> <p>Setpoint Range: Water: 0.1 – 10 fps [0.03 – 3 mps] Hydrocarbon: 0.2 – 20 fps [0.06 – 6 mps] Air: 0.25 – 750 sfps [0.08 – 230 nmms]</p> <p>Repeatability: ± 1% of Setpoint Range</p> <p>Response Time: 0.5 – 7 Seconds</p>												
<p>Maximum Operating Pressure: For Process Connections With: Male NPT / Compression Fitting: 500 psig [35 bar (g)] Butt Weld: 500 psig [35 bar (g)] Flanges (Sanitary): 100 psig [7 bar (g)] (IV) Flanges (ANSI): Per Specification (I, II)</p>	<p>FS2000L Flow Switch (Non-Intrusive)</p> <p>Setpoint Range: Water: 0.1 – 10 fps [0.03 – 3 mps] Air: 0.5 – 300 sfps [0.15 – 91.4 nmms]</p> <table border="1"> <thead> <tr> <th>Tubing</th> <th>Air / Gas</th> <th>Water</th> </tr> </thead> <tbody> <tr> <td>½ inch</td> <td>1.02 – 13.4 scfm [0.000 – 0.38 scmm]</td> <td>0.03 – 3.4 gpm [0.11 – 12.9 lpm]</td> </tr> <tr> <td>1 inch</td> <td>0.12 – 74 scfm [0.0030 – 2.10 scmm]</td> <td>0.18 – 18.5 gpm [0.68 – 70 lpm]</td> </tr> <tr> <td>2 inch</td> <td>0.57 – 342 scfm [0.0160 – 9.70 scmm]</td> <td>0.85 – 85.5 gpm [3.22 – 324 lpm]</td> </tr> </tbody> </table> <p>Repeatability: ± 1% of Alarm Setpoint</p> <p>Accuracy: ± 3% of Alarm Setpoint ± 0.25% of Setpoint Range</p> <p>Response Time: Adjustable from 0.5 – 2.5 Seconds</p>	Tubing	Air / Gas	Water	½ inch	1.02 – 13.4 scfm [0.000 – 0.38 scmm]	0.03 – 3.4 gpm [0.11 – 12.9 lpm]	1 inch	0.12 – 74 scfm [0.0030 – 2.10 scmm]	0.18 – 18.5 gpm [0.68 – 70 lpm]	2 inch	0.57 – 342 scfm [0.0160 – 9.70 scmm]	0.85 – 85.5 gpm [3.22 – 324 lpm]
Tubing	Air / Gas	Water											
½ inch	1.02 – 13.4 scfm [0.000 – 0.38 scmm]	0.03 – 3.4 gpm [0.11 – 12.9 lpm]											
1 inch	0.12 – 74 scfm [0.0030 – 2.10 scmm]	0.18 – 18.5 gpm [0.68 – 70 lpm]											
2 inch	0.57 – 342 scfm [0.0160 – 9.70 scmm]	0.85 – 85.5 gpm [3.22 – 324 lpm]											
<p>Input Power: 24 Vac or Vdc. 3 watts Max. 100 to 240 Vac. 5 watts Max.</p> <p>2-Wire Loop Power (I, II, IV) 22.5 to 33 Vdc .5 watts Max</p>													
<p>Signal Output: <i>Available on 24 Volt and 100 to 240 input power units.</i> Alarm indicator is a 6 amp relay, 28 Vdc / 240 Vdc resistive. Secondary alarm indicator is an open collector circuit (250 mA Maximum). <i>FS2000, FS2000H and LS2000 Only</i>² 2-Wire Loop Power: Alarm indicator responds to change in current draw between 14 mA and 18 mA.</p>													
<p>Installation: Top or Side Mount. Axial flow direction permissible.</p>													
<p>Service: General Purpose for Gases and Liquids</p>													
<p>Agency Approvals: FM, CSA, CE Mark, ATEX, Sanitary 3A, ASME BPE (1997) (IV) FM, CSA, CE Mark, ATEX, Cenelec (I, II) FM, CSA, CE Mark, CRN, ATEX¹ (III)</p>													

NOTES:

1. Special Conditions for Safe Use:
 - a. Provisions shall be made to prevent the rated voltage being exceeded by transient disturbances of more than 40%.
 - b. For applications in explosive atmospheres caused by air/dust mixtures, cable and conduit entries used shall provide a degree of ingress protection of at least IP 54 according to EN 60529.
2. Customer must provide a 4-20mA current loop that will maintain 18 to 29.5 volts at the controller control circuit.
3. Roman Numerals reflect model designation.

Section B - Instrument Installation

For the FS2000, FS2000H and the LS2000, there is an orientation mark  etched onto the sensor element. It is located on a flattened area of the sensor element body close to the housing.

For the LS2000, the orientation mark can be perpendicular or parallel to the liquid level. The sensor element can be installed top mount 90° to the liquid surface.

For the FS2000 and the FS2000H, the orientation mark must be parallel to flow, (± 3°). For liquid vertical flows, FCI recommends that the sensor element be installed where the flow is going in the up direction.

For the FS2000L, there is a flow arrow mark  etched onto the sensor element. It is located on the sensor element body close to the housing. The sensor element can be at any angle as long as the flow direction follows the flow arrow. Liquid applications where the flow element is positioned other than horizontally, FCI recommends that the flow go in the up direction.

For all models, the position of the sensor element in reference to the media is paramount. With this in mind, the position of the control circuit enclosure also needs to be considered. After the sensor element is installed, the enclosure cover must be accessible for wiring and servicing. It is preferred that the conduit port is positioned in a downward direction to reduce the possibility of moisture collecting in the enclosure. The enclosure may be repositioned by up to ½ turn to facilitate conduit installation.

CAUTION: To minimize the possibility of damage, leave the protective covers over the sensing area until the time of installation. Take extra precaution with the sensing elements and surface when installing.

For NPT process connections, apply the appropriate sealant compatible with the process media to the male threads. Tighten until the orientation mark is positioned correctly. Check for leaks.

For flange connections, refer to the installation outline diagrams. The bolt pattern on the process connection flange must be positioned in a way that the orientation mark on the sensor element ends up in the correct position as mentioned above. Use gasket material compatible to the process media. Check for leaks.

For sanitary flange connections, use o-rings compatible with the media. Position the o-ring(s) and join the sanitary flanges. Install the flange clamp(s) snug to permit rotation of the sensor element. Rotate the sensor element until the orientation mark is correctly positioned. Tighten the clamps and check for leaks.

For butt weld connections, make sure all parts are cleaned. Mount the instrument to check fit. Make sure the flow arrow is in the same direction of flow. Align the inside diameter (I.D.) of the instrument to the I.D. of the your piping. Tack weld in place. A qualified welder should perform welding per ASME Section IX, Boiler Code. For best results, 100% penetration with the weld size of 1 1/2 times the wall thickness is desired. Check for leaks.

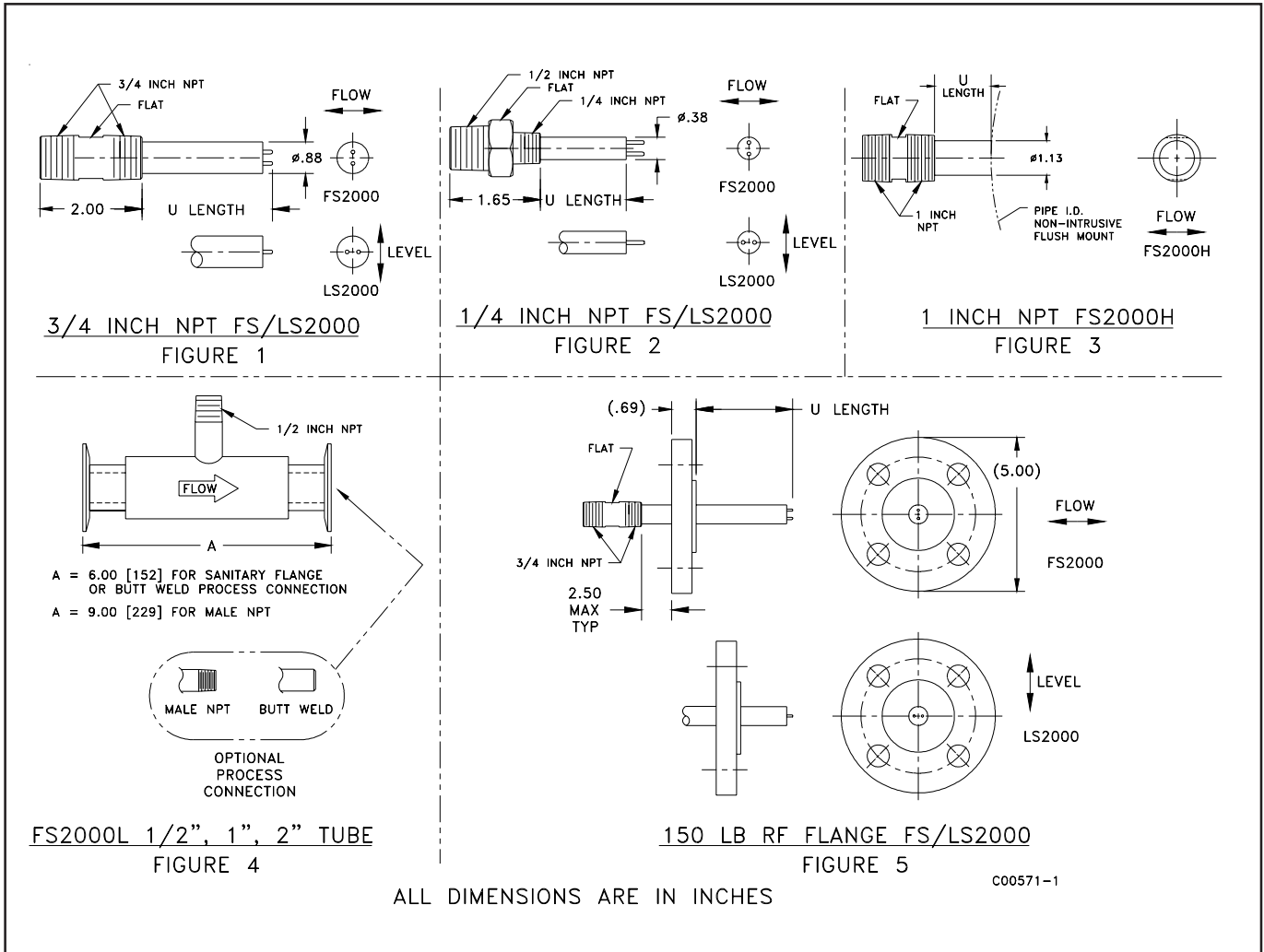

Sensor Element Diagrams

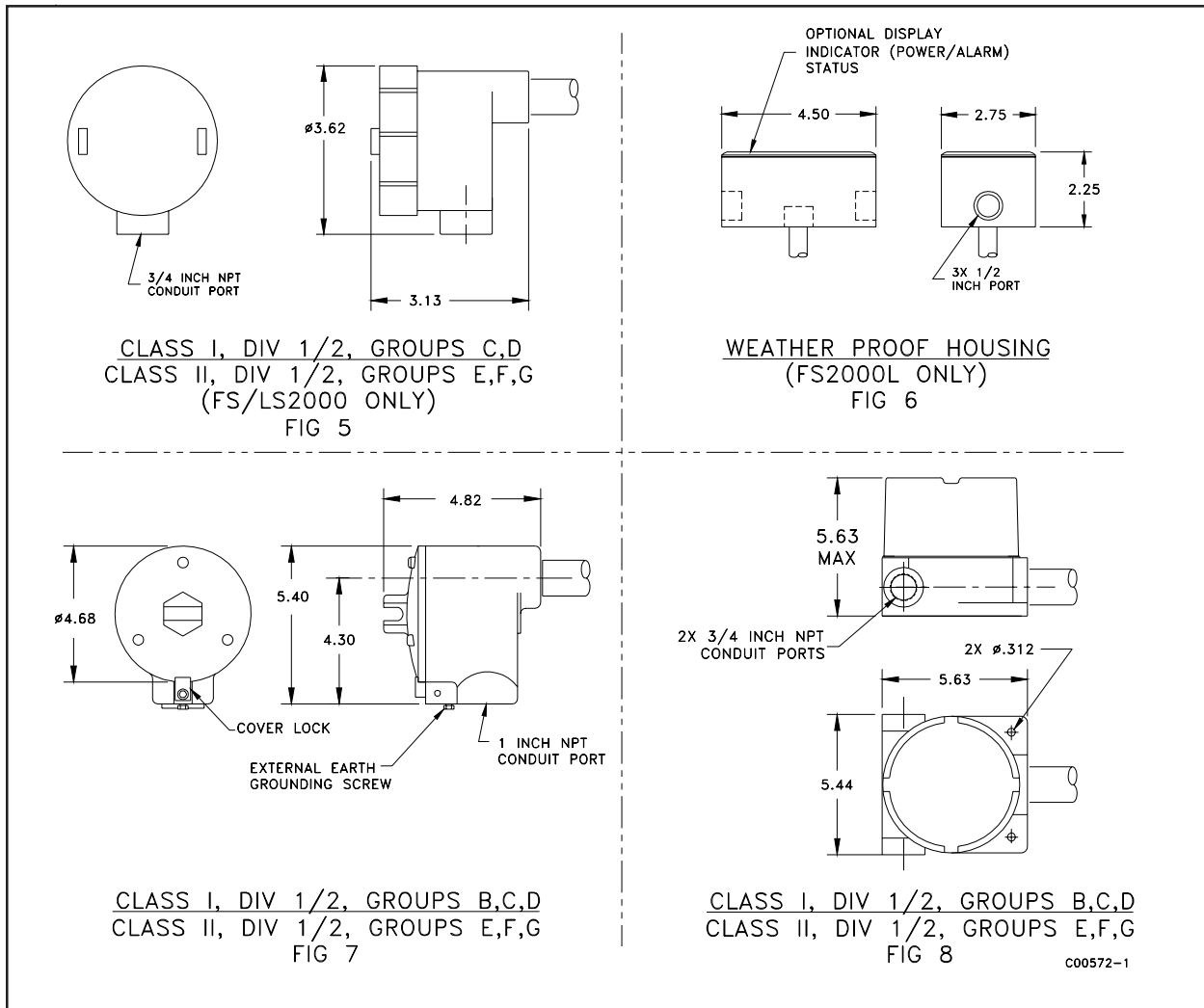

Control Circuit Enclosure Diagrams

Section C - Instrument Wiring

There are three basic wiring configurations with the main difference being the way the instrument is powered. Only qualified personnel are to wire or test this instrument. The operator assumes all responsibilities for safe practices while wiring or troubleshooting. One of the following wiring instruction and diagrams illustrate the requirements for power input, alarm outputs and safety instructions for the unit being installed.



ALERT: The Instrument contains electrostatic discharge (ESD) sensitive devices. Use standard ESD precautions when handling the instrument.

Recommended Minimum Wire Gauge

The following wire gauge chart specifies the correct wire for the distance to the power source or loads. Note that the open collector option is limited to 50 ft. It is also recommended that the open collector cable is shielded and that it is not run in the same conduit with the power source or the relay load.

Connection	Maximum Distance for Wire Gauge					
	10 ft. (3M)	50 ft. (15M)	100 ft. (30M)	250 ft. (76M)	500 ft. (152M)	1000 ft. (305M)
Input Power 100 – 240Vac	22	20	18	16	14	12
Input Power 24(AC or DC)	24	24	22	22	20	18
Loop Power	24	24	22	22	20	18
Relay Output	18	16	14	12	10	x
Open Collector Output	24	22	x	x	x	x

Grounding

The switch must be properly ground for safety and operational reasons.



100 –240 Vac input power units: A minimum gauge of 14AWG is required on the earth ground terminal. This connection should have a resistance to earth ground less than 1 ohm. Do not connect the earth ground to DC ground (terminals marked “GND” or “COM” or “-”).

24 volt and Two wire (loop powered) units: The earth ground wire will be attached to the inside of the enclosure on a grounding screw along with the ground wire from the control circuit. Use the recommended wire gauge specified for the input power and distance listed in the chart above. Do not connect the earth ground to DC ground (terminals marked “GND”, “COM” or “-”).

Input Power, 100-240 Vac

1. FCI recommends installing an input power disconnect and a fuse near the instrument to interrupt power during installation, maintenance, calibration, alarm selection and troubleshooting procedures. Conduit should also be installed according to the local electrical codes or hazardous location requirements. If the wires are to be pulled through the enclosure it is recommended that the control circuits be removed from the housing.
2. Ensure the power is off to the instrument before wiring the instrument.
3. With the enclosure cover removed, locate the 4-40 hold down screw next to the serial number block on the top control circuit (see Figure 12). Loosen the screw to release the edge of the top control circuit and flip up the top circuit to expose the bottom circuit.
Note: The 4-40 screw is captive on the control circuit.
4. If the control circuit requires removal, disconnect the sensor element wires from TB3 using a 3/32" flat head screwdriver. Remove the two Phillips screws on the bottom control circuit and pull the control circuit assembly out of the enclosure enough to expose the ground wire. Disconnect the ground wire and remove the control circuit assembly from the enclosure. After pulling wire to the enclosure, reassemble the control circuit assembly back into the enclosure before wiring the power and output. Make sure the green ground wire is reconnected to the enclosure.
5. Attach the ac power leads to TB4 as indicated on the control circuit. Make sure that an earth ground wire is attached to the earth ground terminal. See figure 9.
6. Attach the relay load wires to TB5. The relay contact conditions are shown in the alarm state (de-energized). The relay's maximum rating is 6 amps 28Vdc-100/240Vac, resistive loads. The minimum current and voltage rating 20mA, 10 volts. If the load is less than the minimum values use the open collector terminal on TB1, top control circuit.
7. After making the connections to TB4 and TB5 (TB1), secure all the wires to the tie down bracket with a cable tie wrap. See figure 9. This is required by safety agencies to act as a strain relief and to prevent fly off of a wire with high voltage potential.
8. After making all the wire connections, flip down the top control circuit and secure it with the 4-40 captive screw.
9. Refer to the next section for functional verification and adjustments.

Input Power, 24 Vdc/Vac

1. FCI recommends installing an input power disconnect and a fuse near the instrument to interrupt power during installation, maintenance, calibration, alarm selection and troubleshooting procedures. Conduit should also be installed according to the local electrical codes or hazardous location requirements. If the wires are to be pulled through the enclosure it is recommended that the electronics be removed from the housing.
2. With the enclosure cover removed, locate the 4-40 hold down screw next to the serial number block on the top control circuit (see Figure 12). Loosen the screw to release the edge of the top control circuit and flip up the top control circuit to expose the terminal blocks on the bottom side.
Note: The 4-40 screw is captive on the control circuit.
3. If the control circuit requires removal, remove the green ground wire going to the ground screw. Disconnect the sensor element wires from TB3 using a 3/32" flat head screwdriver. Position the control circuit at a 45° angle to the plastic standoffs and snap the control circuit off the standoffs. Reinstall the control circuit before connecting the power and loads. To reassemble, snap the control circuit on the plastic standoffs at a 45° angle to the plastic standoffs and reconnect the element wiring.
4. Determine the type of power to be used (24Vac or 24Vdc) and attach the power leads to TB1 as indicated on the control circuit. See Figure 10. Make sure that an earth ground wire is attached to the earth ground terminal inside the housing.
5. Attach the relay load wires to TB2. The relay contact conditions are shown in the alarm state (de-energized). The relay's maximum rating is 6 amps 28Vdc-100/240 Vac, resistive loads. The minimum current and voltage rating 20 mA, 10 volts. If the load is less than these values use the open collector terminal on TB1 See Figure 10.
6. After making all the wire connections, flip down the top control circuit and secure it with the 4-40 captive screw.

Refer to the next section for the set point and alarm state settings.

Input Power, Two Wire (Loop Power)

1. FCI recommends installing an input power disconnect and a 1/8 amp, fast blow fuse near the instrument to interrupt power during installation, maintenance, calibration, alarm selection and troubleshooting procedures. Conduit should also be installed according to the local electrical codes or hazardous location requirements. If the wires are to be pulled through the enclosure it is recommended that the electronics be removed from the housing.
 2. With the enclosure cover removed, slide the control circuit out half way to expose terminal block P1, Figure 13.
 3. If the control circuit requires removal, slide out the control circuit and remove the green ground wire going to the ground screw. Disconnect the sensor element wires from the Ref and Act. Reinstall the control circuit before connecting the power and loads.
 4. Connect the loop power leads to P1 as indicated on the control circuit. See Figure 11. Make sure that an earth ground wire is attached to the earth ground terminal inside the housing. It is very important that the current loop connected to P1 maintains a voltage rang between 18 and 29.5 volts at the control circuit. Figure 11 shows a typical wiring configuration with a current sense device having 250Ω impedance. With this load, the power supply can be 22 to 33Vdc. Check the load impedance of the current sense device and the power supply and see if they are compatible the NuTec instrument.
 5. If the open collector switch is needed, make the connections to P1. See example circuit Figure 11.
 6. After making all the wire connections, slide the control circuit into the housing until it passes the rim of the housing.
- Refer to the next section for the set point and alarm state settings.

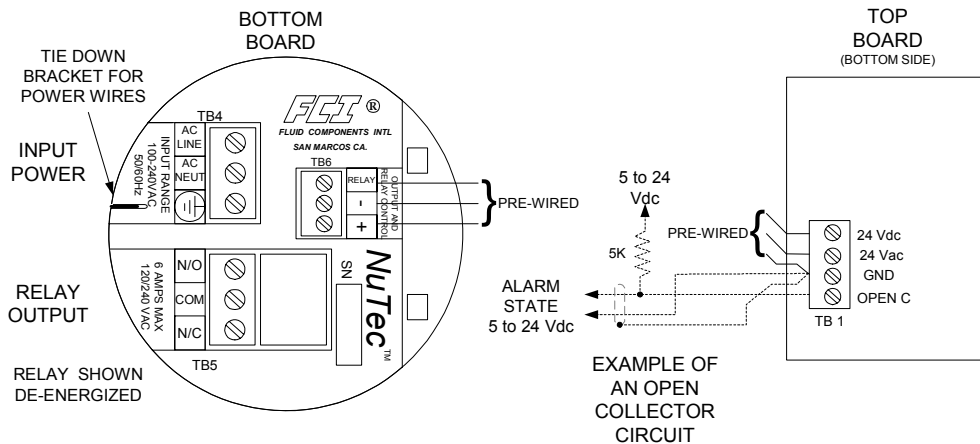

FIGURE 9 100 - 240 Vac Input Power

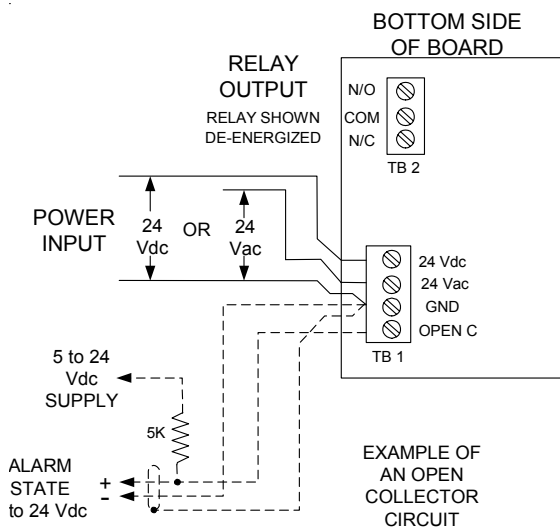

FIGURE 10 24 Vdc / Vac Input Power

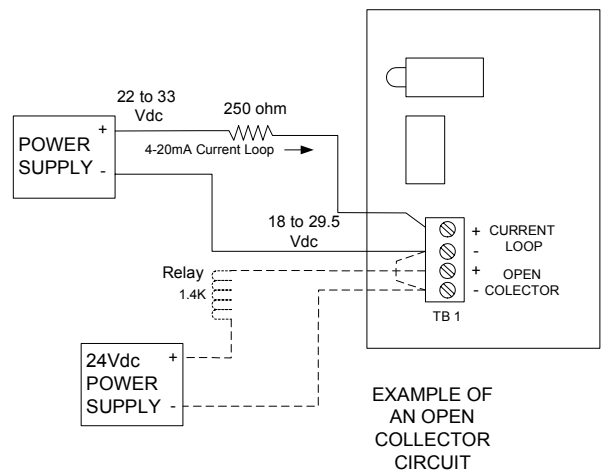

FIGURE 11 2 Wire (Loop Power)

Section D - Power Up, Functional Verification and Adjustment

Before Applying power to the instrument, it is recommended that a third party inspect the installation workmanship. Make sure wires are not pinched or frayed. Check for matching serial numbers on the sensing element and the control circuit. Verify that the power and alarm circuits are properly connected. Review the instrument configuration and its application.

On instruments powered by 100–240Vac or 24Vdc/Vac, the power indicator is a green rectangular LED and the alarm indicator is a red rectangular LED. On instruments powered with two wires (loop power), power is indicated by either one of the red LEDs at the edge of the control circuit. The bottom LED (closest to control circuit) is the flow/wet indicator and the top LED is the no-flow/dry indicator.

Apply power and look for the power indicator light. After power is established let the instrument warm up for 5 minutes. Run the process at normal and then at abnormal conditions. In most cases the instrument will detect a flow or level alarm with the factory settings. If the Instrument does not respond, responds slowly or the alarm responds opposite to the required indication, proceed to the section pertaining to the type of control circuit provided. Refer to Figure 12 and 13 to familiarize yourself with the location of the adjustment potentiometers and jumpers.

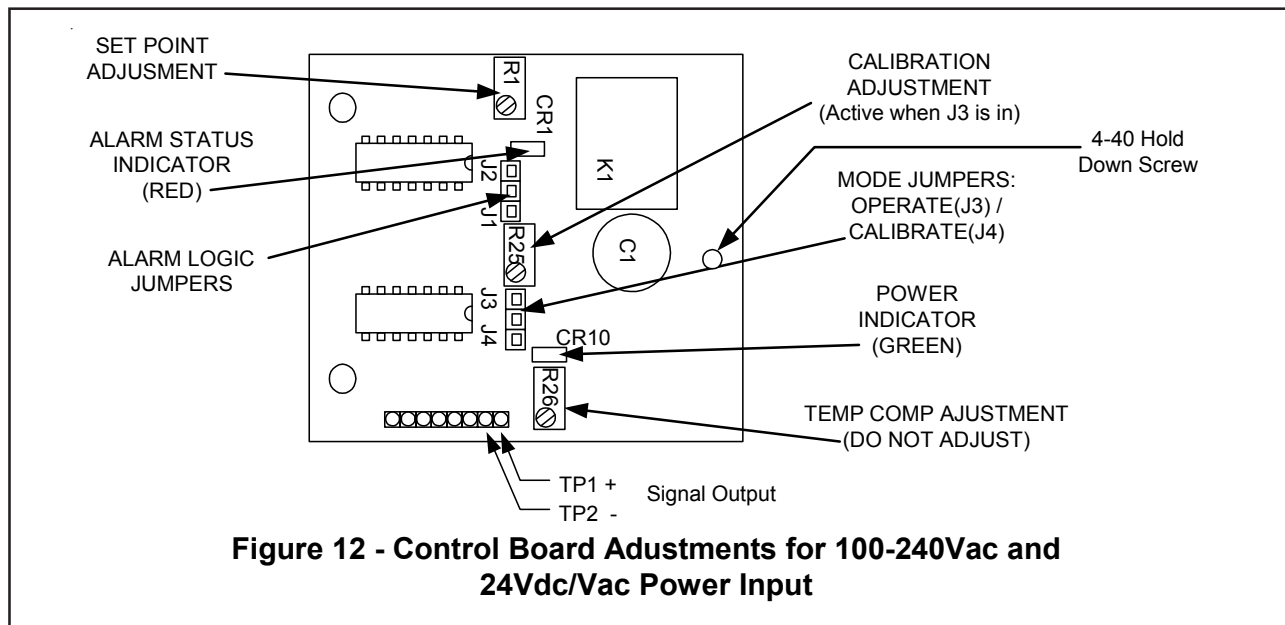

Adjustment by Observation - Input Power, 100-240Vac 24Vdc/Vac

The following instructions are for both flow and [wet/dry] applications. NOTE: Do not adjust R26 located between the green LED and the edge of the control circuit.

Detecting Decreasing Flow or [Dry] (Low Flow/[Dry] Alarm, jumper at J2)

Run the process at normal flow [raise the level]. If the alarm status LED is off, turn the set point adjustment potentiometer (pot) R1 clockwise until LED turns on. With the LED on, slowly turn the pot counterclockwise until the LED just turns off. Adjust the pot one-quarter turn counterclockwise past the point where LED turns off. Stop the process flow [lower level]. And verify that instrument has switched to the alarm state.

Detecting Increasing Flow or [Wet] (High Flow/[Wet] Alarm, jumper at J1)

Run the process at normal flow [lower the level]. If the alarm status LED is off, turn the set point adjustment potentiometer (pot) R1 clockwise until LED turns on. With the LED on, slowly turn the pot counterclockwise until the LED just turns off. Adjust the pot one-quarter turn counterclockwise past the point where LED turns off. Increase the process flow [raise level]. And verify that instrument has switched to the alarm state.

Adjustment by Measurement - Input Power, 100-240Vac 24Vdc/Vac

The following instructions are for both flow and [wet/dry] applications. Verify that the mode jumper is in the operation position (J3). Attach a DVM to TP1(+) and TP2(-). Establish a normal flow [wet or dry] condition, letting the instrument stabilize. Record the TP1 to TP2 voltage. Go to one of the following procedures as applicable.

NOTE: Do not adjust R26 located between the green LED and the edge of the control circuit.

Detecting Decreasing Flow or [Dry] (Low Flow/[Dry] Alarm, jumper at J2)

Stop the process flow [lower level] allowing the instrument to stabilize. Record the TP1 to TP2 voltage. Average the normal and the abnormal process condition voltages (i.e., if the normal reading is 7 volts and the abnormal reading is 8 volts, the average or set point is 7.5 volts). The calculated set point must be at least 0.04 volts over the normal condition. Change the mode jumper to the Calibrate (Cal) position, (J4). Adjust the cal pot (R25) until the DVM equals the calculated set point voltage. If the Red LED is off, turn the set point pot slowly counterclockwise until the LED turns on. If the LED is on, turn the pot (R1) clockwise until the LED turns off, then slowly turn the pot counterclockwise until the LED just turn on. Set the calibration jumper to the operate position (J3).

Detecting Increasing Flow or [Wet] (High Flow/[Wet] Alarm, jumper at J1)

Start an excessive process flow [raise level] allowing the instrument to stabilize. Record the TP1 to TP2 voltage. Average the normal and the abnormal process condition voltages (i.e., if the normal reading is 7 volts and the abnormal reading is 6 volts, the average or set point is 6.5 volts). The calculated set point must be at least 0.04 volts below the normal condition. Change the mode jumper to the Calibrate (Cal) position, (J4). Adjust the cal pot (R25) until the DVM equals the calculated set point voltage. If the Red LED is on, turn the set point pot slowly counterclockwise until the LED turns off. If the LED is off, turn the pot (R1) clockwise until the LED turns on, then slowly turn the pot counterclockwise until the LED just turn off. Set the calibration jumper to the operate position (J3).

Adjustment by Observation - Input Power, Two Wire (Loop Power)

The following instructions are for both flow and [wet/dry] applications.

NOTE: Do not adjust R32A and R35A located in the middle of the control circuit.

Detecting Flow or [Wet (high level alarm)]

Set J1 to the “Wet/Flow” position. With the sensing element at no-flow or [dry], turn the set point potentiometer (pot) to the point where the LEDs toggle back and forth (clockwise to turn on the top LED, CR3, and counterclockwise to turn on the bottom LED, CR2). Turn the pot one turn clockwise past the point where the top LED (CR3) turns on. Turn on the flow [raise liquid level] and verify that the instrument switches to the alarm state when flowing or [wet].

Detecting No-Flow or [Dry (low level alarm)]

Set J1 to the “Dry/No-Flow” position. With the sensing element at flow or [wet], turn the set point potentiometer (pot) to the point where the LEDs toggle back and forth (clockwise to turn on the top LED, CR3, and counterclockwise to turn on the bottom LED, CR2). Turn the pot one turn counterclockwise past the point where the bottom LED (CR2) turns on. Stop the flow [lower liquid level] and verify that the instrument switches to the alarm state when not flowing or [dry].

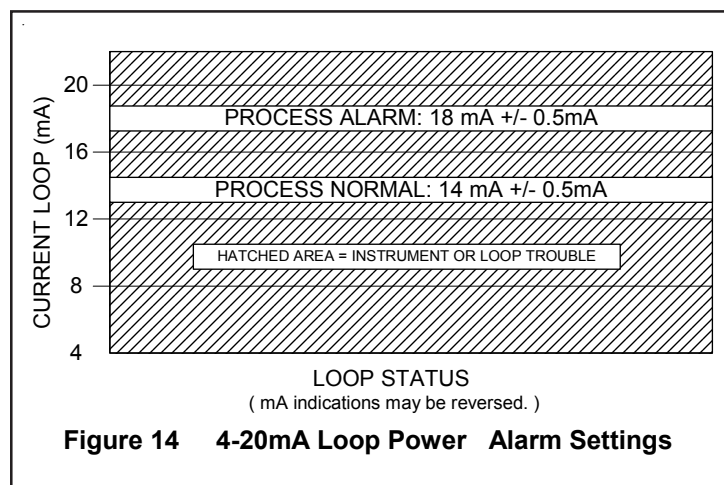
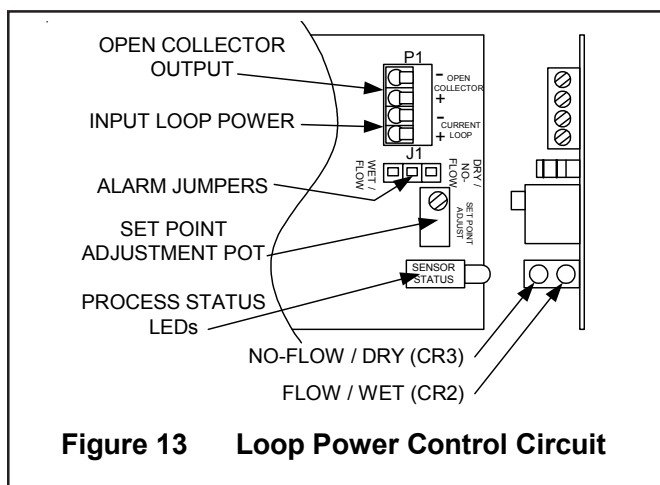
**Section E - Maintenance and Troubleshooting**

Maintenance: Typically required for the sensing element. If the process media sticks to the process pipes (or tank) the sensing element should be cleaned in the same manner and frequency as the process pipe (or tank). Occasionally check for moisture in the control circuit housing and wiring connections. Check for proper functionality and response time.

Troubleshooting: If the instrument is not operating, go through the installation and adjustment procedures and verify proper installation. If the instrument fails after some time in service and it has been checked, or if it fails to operate at start up and the installation has been verified, contact FCI Technical Service. If the instrument is to be returned, obtain a Return Authorization. The form contains a declaration of decontamination cleaning information that the instrument must comply with before it is shipped to FCI. The telephone number is 1-800-854-1993 or 1-760-744-6950.

Section F - Approval Information**CE
Information**

**CE DECLARATION OF CONFORMITY
FS2000/LS2000/FS2000L/FS2000H Series**

We, *Fluid Components Intl*, located at 1755 La Costa Meadows Drive, San Marcos, California 92069-5187 USA, declare under our sole responsibility that the **FS2000/LS2000/FS2000L/FS2000H Series, Flow and Level Monitoring Switches**, to which this declaration relates, are in conformity with the following standards and Directives.

EMC Directive 89/336/EEC, May 3, 1989 of the **European Union**

Immunity specification: EN 61000-6-2 /1998, EN 61000-4-2,-3,-4,-5 /1995, EN 61000-4-6 /1996
EN 61000-4-11 /1994 (FS2000L only)

Emissions specification: EN55022 1998 Class A and CISPR 22 1997 Class A.
(Conducted emissions not tested, not applicable for industrial standard)

Pressure Equipment Directive 97/23/EC.

The FS2000, LS2000 and FS2000H Models do not have a pressure bearing housing and are therefore not considered as pressure equipment by themselves according to article 1, section 2.1 of the Directive. Model FS2000L is in conformity with the sound engineering practices as defined in the **Pressure Equipment Directive (PED) 97/23/EC** article 3, paragraph 3, instruments with a line size greater than 25 mm are limited by the requirements of Annex II, table 6 as define in article 3 section 1.3.

*Issued at San Marcos, California USA
23, June 2004*

Eric J. Wible, Engineering Manager

Flow/Liquid Level/Temperature Instrumentation

Visit FCI on the Worldwide Web: www.fluidcomponents.com
1755 La Costa Meadows Drive, San Marcos, California 92069 USA 760-744-6950 • 800-854-1993 • 760-736-6250
European Office: Persephonestraat 3-01 5047 TT Tilburg – The Netherlands – Phone 31-13-5159989 • Fax 31-13-5799036

Doc no. 23EN000008B

Safety Instructions for the use of the FS2000L, FS2000 and LS2000 Flow & Level Monitoring Switches in Hazardous Areas

Approval KEMA 04 ATEX 1135X for Category II 3GD protection EEx nA II T6 T62°C
Category II 3GD protection EEx nC IIC T6 T62°C

Dansk	Sikkerhedsforskrifter	Italiano	Normative di sicurezza
Deutsch	Sicherheitshinweise	Nederlands	Veiligheidsinstructies
English	Safety instructions	Português	Normas de segurança
Υπ	Υπ_δεί_εις_ασφαλείας	Español	Instrucciones de seguridad
Suomi	Turvallisuusohjeet	Svenska	Säkerhetsanvisningar
Français	Consignes de sécurité		

DK Dansk- Sikkerhedsforskrifter

Disse sikkerhedsforskrifter gælder for Fluid Components, FS2000L, FS2000 and LS2000 Flow & Level Monitoring Switches EF-typeafprøvningsattest-nr. KEMA 04 ATEX 1135X (attestens nummer på typeskiltet) er egnet til at blive benyttet i eksplosiv atmosfære kategori II 3 GD.

- 1) Ex-anlæg skal principielt opstilles af specialiseret personale.
- 2) FS2000L, FS2000 and LS2000 Flow & Level Monitoring Switches skal jordforbindes.

D A Deutsch-Sicherheitshinweise

Diese Sicherheitshinweise gelten für die Fluid Components, FS2000L, FS2000 and LS2000 Flow & Level Monitoring Switches gemäß der EG-Baumusterprüfbescheinigung Nr. KEMA 04 ATEX 1135X (Bescheinigungsnummer auf dem Typschild) der Kategorie II 3 GD.

- 1) Die Errichtung von Ex-Anlagen muss grundsätzlich durch Fachpersonal vorgenommen werden.
- 2) Der FS2000L, FS2000 and LS2000 Flow & Level Monitoring Switches muß geerdet werden.

GB IRL English- Safety instructions

These safety instructions are valid for the Fluid Components, FS2000L, FS2000 and LS2000 Flow & Level Monitoring Switches to the EC type approval certificate no. KEMA 04 ATEX 1135X (certificate number on the type label) for use in potentially explosive atmospheres in Category II 3 GD.

- 1) The installation of Ex-instruments must be made by trained personnel.
- 2) The FS2000L, FS2000 and LS2000 Flow & Level Monitoring Switches must be grounded.

GR Υπ_δεί_εις_ασφαλείας

Αυτές οι οδηγίες ασφαλείας ισχύουν για τα Ροόμετρα της Fluid Components τύπου FS2000L, FS2000 and LS2000 Flow & Level Monitoring Switches που φέρουν Πιστοποιητικό Έγκρισης Ευρωπαϊκής Ένωσης, με αριθμό πιστοποίησης KEMA 04 ATEX 1135X (ο αριθμός πιστοποίησης βρίσκεται πάνω στην ετικέτα τύπου του οργάνου) για χρήση σε εκρηκτικές ατμόσφαιρες της κατηγορίας II 3 GD.

- 1) Η εγκατάσταση των οργάνων με αντιεκρηκτική προστασία πρέπει να γίνει από εξειδικευμένο προσωπικό.
- 2) Το όργανο τύπου FS2000L, FS2000 and LS2000 Flow & Level Monitoring Switches πρέπει να είναι γειωμένο.

FIN Suomi - Turvallisuusohjeet

Nämä turvallisuusohjeet koskevat Fluid Components, FS2000L, FS2000 and LS2000 Flow & Level Monitoring Switches EY-tyyppitarkastustodistuksen nro. KEMA 04 ATEX 1135X mukaisesti (todistuksen numero näkyy tyyppikilvestä) käytettäessä räjähdysvaarallisissa tiloissa luokassa

- 1) Ex-laitteet on aina asennettava ammattihenkilökunnan toimesta.
- 2) FS2000L, FS2000 and LS2000 Flow & Level Monitoring Switches on maadoitettava.

F B L Consignes de sécurité

Ces consignes de sécurité sont valables pour le modèle FS2000L, FS2000 and LS2000 Flow & Level Monitoring Switches de la société Fluid Components (FCI) conforme au certificat d'épreuves de type KEMA 04 ATEX 1135X (numéro du certificat sur l'étiquette signalétique) conçu pour les applications dans lesquelles un matériel de la catégorie II 3 GD est nécessaire.

- 1) Seul un personnel spécialisé et qualifié est autorisé à installer le matériel Ex.
- 2) Les FS2000L, FS2000 and LS2000 Flow & Level Monitoring Switches doivent être reliés à la terre.

I Italiano - Normative di sicurezza

Queste normative di sicurezza si riferiscono ai Fluid Components, FS2000L, FS2000 and LS2000 Flow & Level Monitoring Switches secondo il certificato CE di prova di omologazione n° KEMA 04 ATEX 1135X (numero del certificato sulla targhetta d'identificazione) sono idonei all'impiego in atmosfere esplosive applicazioni che richiedono apparecchiature elettriche della Categoria II 3 GD.

- 1) L'installazione di sistemi Ex deve essere eseguita esclusivamente da personale specializzato.
- 2) I FS2000L, FS2000 and LS2000 Flow & Level Monitoring Switches devono essere collegati a terra.

NL B Nederlands - Veiligheidsinstructies

Deze veiligheidsinstructies gelden voor de Fluid Components, FS2000L, FS2000 and LS2000 Flow & Level Monitoring Switches overeenkomstig de EG-typeverklaring nr. KEMA 04 ATEX 1135X (nummer van de verklaring op het typeplaatje) voor gebruik in een explosieve atmosfeer volgens Categorie II 3 GD

- 1) Installatie van Ex-instrumenten dient altijd te geschieden door geschoold personeel.
- 2) De FS2000L, FS2000 and LS2000 Flow & Level Monitoring Switches moet geaard worden.

P Português - Normas de segurança

Estas normas de segurança são válidas para os Fluid Components, FS2000L, FS2000 and LS2000 Flow & Level Monitoring Switches conforme o certificado de teste de modelo N.º KEMA 04 ATEX 1135X (número do certificado na plaqueta com os dados do equipamento) são apropriados para utilização em atmosferas explosivas categoria II 3GD

- 1) A instalação de equipamentos em zonas sujeitas a explosão deve, por princípio, ser executada por técnicos qualificados.
- 2) Os FS2000L, FS2000 and LS2000 Flow & Level Monitoring Switches precisam ser ligados à terra.

E Español - Instrucciones de seguridad

Estas indicaciones de seguridad son de aplicación para el modelo FS2000L, FS2000 and LS2000 Flow & Level Monitoring Switches de Fluid Components, según la certificación CE de modelo N° KEMA 04 ATEX 1135X para aplicaciones en atmósferas potencialmente explosivas según la categoría II 3GD (el número de certificación se indica sobre la placa informativa del equipo).

- 1) La instalación de equipos Ex tiene que ser realizada por personal especializado.
- 2) Los FS2000L, FS2000 and LS2000 Flow & Level Monitoring Switches tienen que ser conectados a tierra.

S Svenska - Säkerhetsanvisningar

Säkerhetsanvisningarna gäller för Fluid Components, Flödesmätare typ FS2000L, FS2000 and LS2000 Flow & Level Monitoring Switches enligt EG-typkontrollintyg nr KEMA 04 ATEX 1135X (intygsnumret återfinns på typskylten) är lämpad för användning i explosiv gasblandning i kategori II 3 GD.

- 1) Installation av Ex- klassade instrument måste alltid utföras av fackpersonal.
- 2) FS2000L, FS2000 and LS2000 Flow & Level Monitoring Switches måste jordas.



FCI's Complete Customer Commitment. Worldwide
ISO 9001:2000 and AS9100 Certified

Notice of Proprietary Rights

This document contains confidential technical data, including trade secrets and proprietary information which is the property of Fluid Components International LLC (FCI). Disclosure of this data to you is expressly conditioned upon your assent that its use is limited to use within your company only (and does not include manufacture or processing uses). Any other use is strictly prohibited without the prior written consent of FCI.

Visit FCI on the Worldwide Web: www.fluidcomponents.com
1755 La Costa Meadows Drive, San Marcos, California 92078 USA - 760-744-6950 - 800-854-1993 - Fax 760-736-6250