

ST98 HART Option Installation and Operation Guide

This manual is used to augment other instrument manuals when the HART option is used. **NOTE:** ST98 HART supports “Normal Mode” and it does not support “Burst Mode”.

Step 1. Installation

Use the following steps to install the HART option for the ST98:

1. All the FCI transmitters that incorporate the HART protocol are set at the factory to polling address “0”. Users should reset the polling address to match the needs of their network.
2. At polling address “0”, the ST98 outputs a current of 4 - 20mA; at any other polling address, the ST98 outputs a fixed 4mA current; in compliance with the HART standard. A digital signal is provided with all polling addresses.
3. If the ST98 is going to be used as a HART network transmitter, the polling address needs to be changed to other than “0”.
4. All the FCI transmitters that incorporate the HART protocol are configured by the factory as a current source; and JP1 through JP3 are set for “Internal Power” by the factory.
5. When the ST98 is connected in a HART Network a recommendation is the instrument be configured for an external current source by resetting JP1, JP2, and JP3 on the Input/Output Board, and the polling address must be changed to other than “0”. The power supply feeding the network must provide sufficient current to support the instruments in the network.

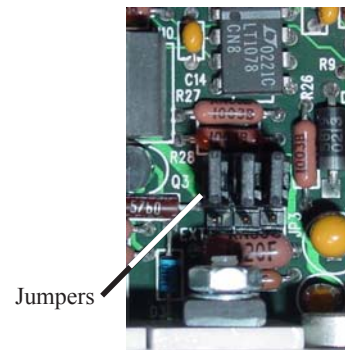
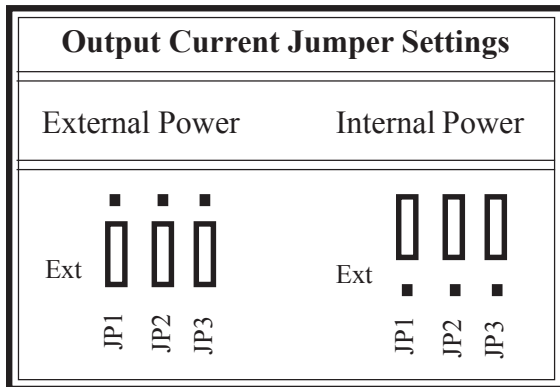

ST98 Input/Output Board
Internal Power setting shown

Notice of Proprietary Rights

This document contains confidential technical data, including trade secrets and proprietary information which is the property of Fluid Components International LLC (FCI). Disclosure of this data to you is expressly conditioned upon your assent that its use is limited to use within your company only (and does not include manufacture or processing uses). Any other use is strictly prohibited without the prior written consent of FCI.

Visit FCI on the Worldwide Web: www.fluidcomponents.com

1755 La Costa Meadows Drive, San Marcos, California 92078 USA - 760-744-6950 - 800-854-1993 - Fax 760-736-6250

Step 2. Wiring the Hart Instrument

INPUT POWER - Follow the ST98 manual to connect power. The power is also connected per the face of the circuit board below.

OUTPUT SIGNAL - Connect the 4-20 signal output per the face of the circuit board below.

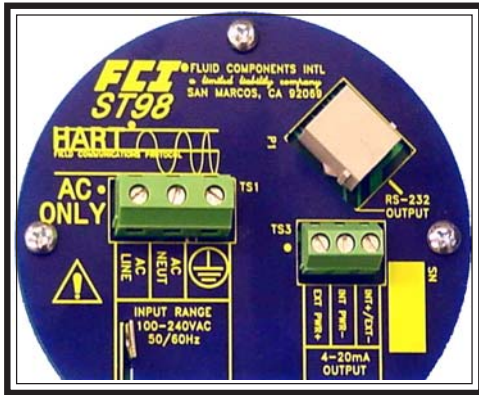

AC Power Input

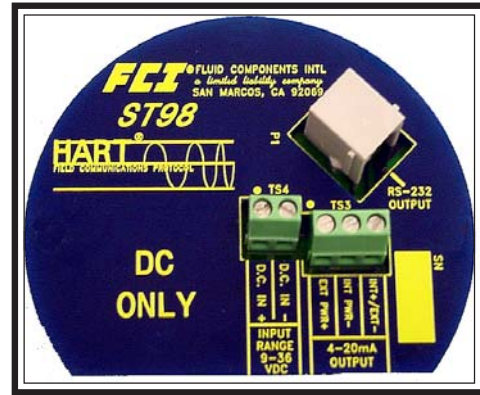

DC Power Input

MULTIPOINT DROP LOOP OUTPUT:

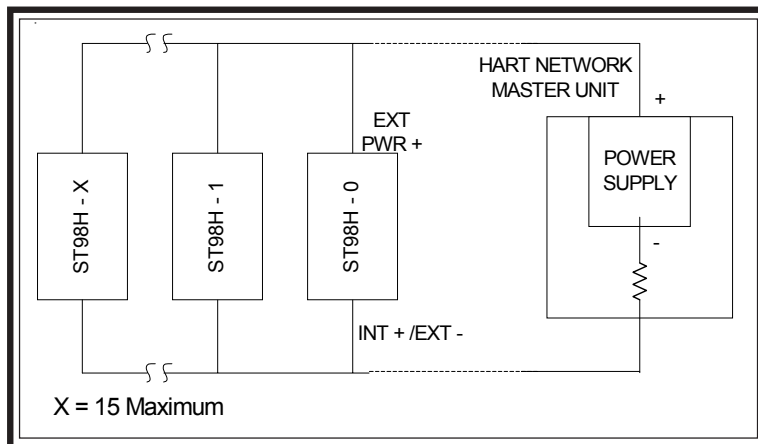

Step 3. Programming the Hart Instrument

Using the HART 275 Communicator with the ST98 Series:

Universal Commands (commands 0-33) can be accessed with no additional programming of the Customer's 275 Communicator. This means that they can read Flow Rate, Temperature and Totalizer values.

FCI Specific Commands (commands 128 and above) require that the Communicator be sent to a HART Foundation Programming Center to have it programmed for the FCI specific commands. HART Programming Centers are capable of programming the Communicator to allow it to access all commands. This will allow the user to access all diagnostic and test functions available in the ST98.

To find a Programming Center nearest the user, access the HART Foundation Web site at www.hartcomm.org.

ST98 HART MENU TREE

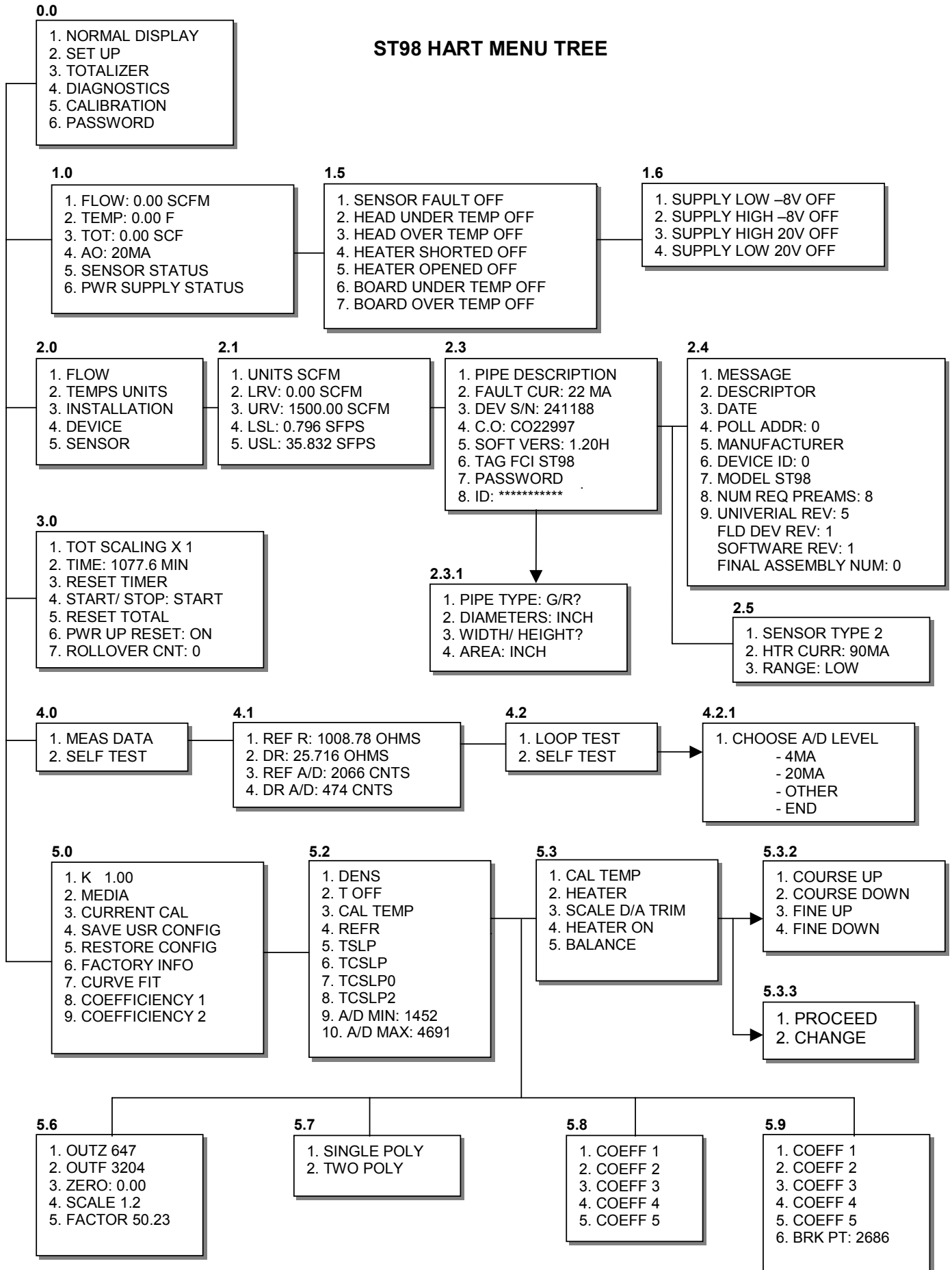

GLOSSARY OF TERMS

General Note: Wherever the word “Procedure” appears this is just a definition of the form of the menu. It has no significance to the user.

1. Normal Display

This menu is analogous to the normal display of the ST98, displaying data continuously.

- Flow – Flow rate in the currently selected units
- Temperature – Medium temperature in the currently selected units
- Total – Totalizer value
- AO – The current in milliamps on the 4-20 ma output
- Fault – A message displaying any current fault condition

2. Setup/Flow - Installation

- Flow LRV – Lower Range Value. This is the set lower value for the 4-20 ma output. It is the same as “zero” in the ST98.
- Flow URV – Upper Range Value. This is the set upper value for the 4-20 ma output. It is the same as “FS” in the ST98.
- Flow LRL – Lower Range Limit. The lower limit on the calibrated range of the instrument. It is the same as “min” in the ST98.
- Flow URL – Upper Range Limit. The upper limit on the calibrated range of the instrument. It is the same as “max” in the ST98.
- Temp Units – The currently selected temperature units are displayed. They cannot be changed because they are set by the selection of the flow units as is done in the ST98.
- Sensor – Selection of the sensor “type”, which sets the heater current and range.
- Device S/N – The flowmeter serial number assigned at the factory
- C.O. – Customer Order number.
- Soft Vers – FCI Software Version number.
- Tag – Users’s tag number

2.5 Setup/Device

This menu provides all of the unique Hart interface information and setups

- Message – This is a “scratch pad” where the user can leave a message.
- Descriptor – A description of the installation that the user can enter.
- Date – User entered date for the installation.
- Poll Addr – The polling address (0-15). If the instrument is part of a data bus, this is the unique address that identifies the instrument.
- Manufacturer – Identification of FCI as the manufacturer.
- Device ID – A unique identification number assigned by the Hart Communications Foundation for the ST98.
- Model – The model number of the instrument, i.e. ST98.
- Num req preams – The number of preambles required to initiate Hart communication. Read Only.
- Universal Rev – The revision of the Hart Communication Foundation (HCF) protocol for which the flowmeter is compliant.
- Field Device Rev – The revision letter of the flowmeter.
- Software Rev – The revision letter of the flowmeter software.
- Final Assembly Number – The part number of the flowmeter.

3. Totalizer

- Tot Scaling – This is the so-called “Kodak” scaling selection. It sets the display format on the instrument to normal or $X10^3$.
- Time – Display of the time since the totalizer was reset.
- Reset Timer – Reset the totalizer timer
- Start/Stop – Start or Stop the totalizer. The totalizer is also reset in this menu.
- [Reset] – *this has been deleted from this position in the menu tree*
- Power Up Reset – Specify that totalizer resets every time the instrument is powered up.
- Rollover Cnt – Display of the number of times the totalizer display has rolled over. The display rolls over when the count exceeds $1E9$ in the current display units.

4. Diagnostics

1. Meas Data – Real time display of measured reference resistance, delta R, the reference resistance A/D count, and the delta R A/D count.
2. Self Test/Loop Test – Test of the 4-20 ma loop to verify its integrity.
3. Self Test/Self Test – All self tests currently run by the ST98 are run and the results displayed.

5. Calibration

1. Group – 5. Media – Calibration coefficients the same as the ST98.

6. Current Cal

1. Heater Adjust – The procedure for adjusting the heater current. Method is identical to the ST98.
2. Scaled D/A Trim – The procedure for adjusting the 4-20 ma output. This method is a Hart standard method.
3. Heater ON/OFF – Turn the heater current ON or OFF. Similar to menu ‘H’ in the ST98.
4. Balance – The procedure for adjusting the balance. Method is identical the ST98.
5. Cal Temp – Display of cal temp for balance procedure.
7. Save User Config. – Save the current setup to the User segment of the permanent memory. Same as the ST98.
8. Restore Config. – Procedure to restore a previously saved setup from the user’s setup, the factory (as-built) setup, or a default setup.
9. Factory info – Read Only display of calibration and setup factors (ST98).